

Technical Specification Sheet

product range: APC40
model: Box Bar Double Glazed

ref no 003/04

The APC40 range offers a selection of slimline box type glazing bars that are suitable for single and double glazed applications with a choice of external decorative cappings. The box bar gives clean elegant sight lines internally and can be used as transoms at glass joint positions. Internal thermal break sections give improved U-value properties.

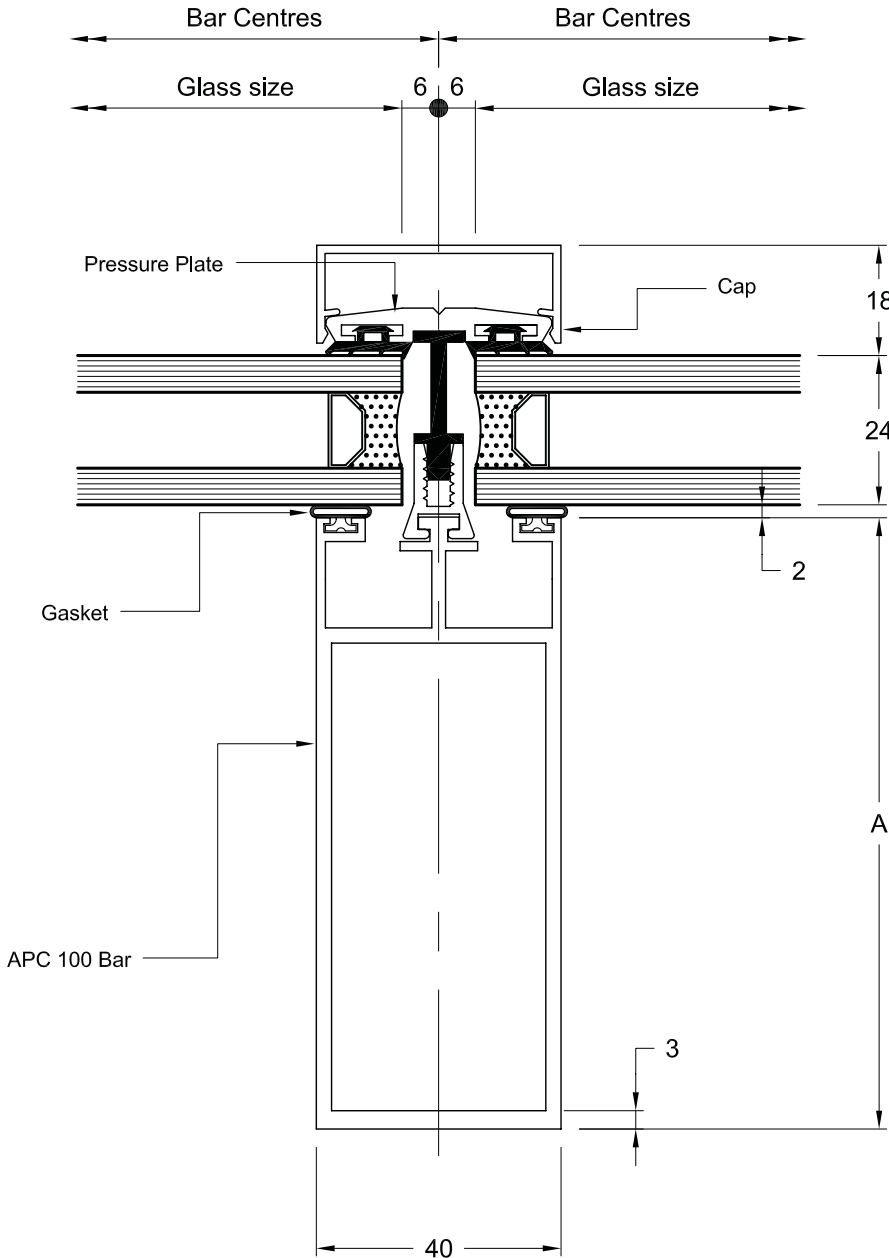

Specification

Glazing bars, cappings, glass stops and fixing cleats are extruded aluminium alloy 6063-T6 to BS 1474. Fasteners are either stainless steel to BS EN ISO 3506 Grade A2 or mild steel bright zinc plated. Gaskets are extruded from Thermo Plastic Rubber quality to BS 7412.

Performance

This system is designed to conform with the requirements of BS 5516, 1991 when designed and installed to Architectural Products recommendations.

Appearance

Materials are available in mill finish, polyester powder coated to BS 6496 to a range of syntha pulvin or RAL colours or anodized to BS3987.

Ventilation

Ventilation may be achieved either through our top hung roof vent inserts or by casement windows to vertical applications. Factory fitted opening mechanisms are available including manual, pole or cord and electrical openers with rain and heat controls.

Infill

All specifications of 24, 28 or 32mm sealed double glazed units can be accommodated by this system. Double glazed units should feature a suitable step to the bottom edge to avoid thermal fracture and breakdown of the unit.

BAR \ DIM	A	Span*
APC 75	75.0	2000
APC 100	100.0	3000
APC 125	125.0	3500

All Dimensions In Millimetres

* Between Fixing Points
@ 600 Bar Centres

 architectural products limited

specialised aluminium fabrications for the construction industry